

INCIDENT COMMAND POST SYSTEM

In use with Joint Task Force Civil Support, the Incident Command Post System (ICPS) is a lightweight, mobile solution to bringing operations directly into the field. Consisting of a state-of-the-art trailer and military-grade shelter that can be set up in minutes, the ICPS ensures that personnel have the space they need during any mission.

Lightweight and Transportable

With a starting weight of less than 3,200 pounds, the Incident Command Post System trailer is lightweight enough to be towed behind most vehicles and offers better gas mileage than larger traditional command trailers. The ICPS trailer can also travel off road, ensuring that it can be deployed to even the most remote sites.

A Solid Shelter Solution

The ICPS's shelter is based on the Deployable Rapid Assembly Shelter (DRASH) that has been trusted by military forces around the world for more than 25 years. The shelter, which is available in three different sizes ranging from 109 to

214 square feet of a usable space, is lightweight, portable, rugged, reliable and user-friendly. There are also no loose parts to misplace - just take it out of the trailer and it's ready to use in minutes. Additionally, the ICPS's shelter can be connected to other DRASH shelters to expand operations as needed.

Numerous Configurations

From a command center to a mobile aid station able to store all of your medical supplies, the ICPS can provide you with the perfect space to meet your unit's or agency's needs.

To learn more, please contact a DRASH representative.

	Part Number	Description
Select One	1008515	Trailer Assy,ICPS,Tan,Diesel
	1011127	Trailer Assy,ICPS,White,Diesel
	1010319	Trailer Assy,ICPS,Black,Diesel
	1011125	Trailer Assy,ICPS,Red,Diesel
	1011126	Trailer Assy,ICPS,Blue,Diesel
	1010754	Trailer Assy,ICPS,Tan,Gas
	1010306	Trailer Assy,ICPS,White,Gas
	1011128	Trailer Assy,ICPS,Black,Gas
	1011129	Trailer Assy,ICPS,Red,Gas
	1011130	Trailer Assy,ICPS,Blue,Gas
Select One	1009131	Cabinet Assy, ICPS, Base Model
	1010275	Cabinet Assy, ICPS, POD Point of Distribution
Select One	1010887	Shelter,ICPS2,Green
	1003678	Shelter,ICPS2,Tan
	1008896	Shelter,ICPS3,Green
	1003679	Shelter,ICPS3,Tan
	1010614	Shelter,ICPS4,Green
Boot to Connect Trailer and Shelter	1004084	Shelter,ICPS4,Tan
	1003458	Collar,ICPS Trailer
Select One	RDL0002	Light,50W,Reeves,Stringable
	H300000-2S	Light Set,Two Fixture,110Watt





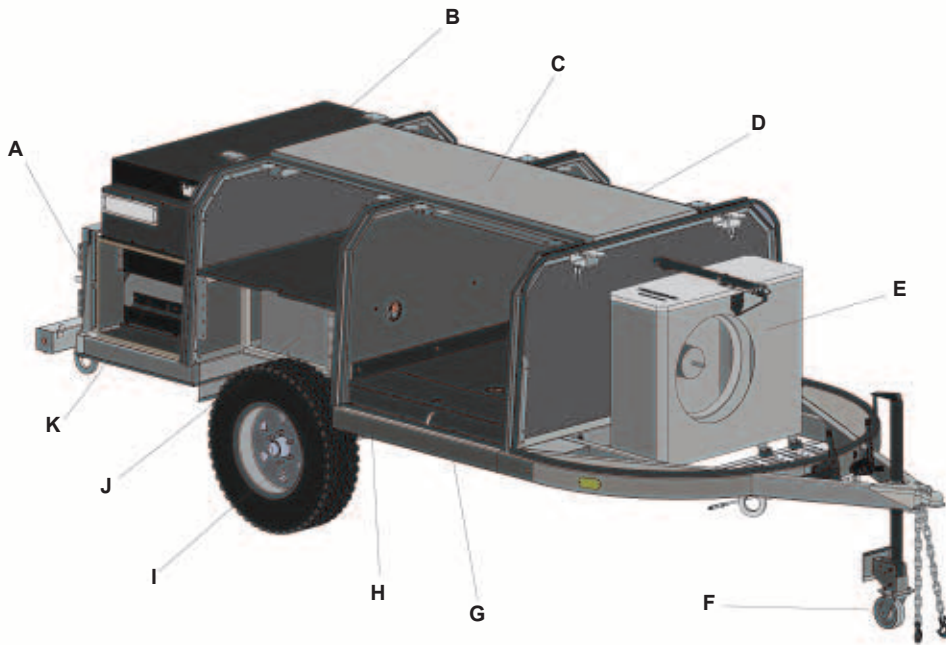

A. Tailgate

Tailgate with folding tables.

B. Equipment Console

Constructed of high-quality, durable material. Can hold a wide range of emergency response equipment.

C. Metal Plate on Top of Trailer

Easily accommodates racks.

D. Shelter Storage

Roomy storage compartment offers plentiful space.

E. Outdoor Condenser Unit

Helps provide heating and cooling throughout command post.

F. Dolly Wheel with Swivel Foot Plate

Allows trailer to park on soft ground without sinking.

G. Integrated Fuel Tank

Fuel tank mounted beneath floor area has approximately 36 hours of run time before refueling.

H. Heavy-Duty Axle

Axle rated at 4,500 pounds.

I. High Profile All-Terrain Tires

Allows trailer to travel on both improved and unimproved roads.

J. Generator and Battery Compartment

8.5 kW diesel-powered generator. Optima "yellowtop" battery 12v (group 31) sealed.

K. Environmental Control Unit (ECU)

ECU provides 24,000 BTUs of cooling and heating.

With a starting weight of less than 3,200 pounds and a foot of ground clearance, the ICPS's trailer is built to go anywhere you need to be.

Features:

- Trailer axle clearance at lowest point is 12".
- 4,500 lbs heavy-duty rated axle
- Includes a 4" steel chassis for superior suspension and steel-rimmed tires.
- Features a 25 degree departure angle.
- Brake lights are standard 7 way hook up to tow vehicle.
- Electric brakes with mechanical park feature.
- Safety chain is welded to the trailer chassis for safety and theft prevention.
- Towable with standard 2" ball.
- Powder-coated chassis prevents rust accumulation and fading.
- Thermo-plastic exterior body panels are resistant to sunlight and fading and pass stringent automotive standards for long-term durability, weatherability, and sunlight exposure.
- Exterior of off-road trailer can be cleaned using mild dish detergent or household cleaner such as Pine Sol (no waxes or special cleaners are needed or recommended).
- All hinges, connecting points, etc. can be lubricated using white lithium grease.
- All compartment doors use gas springs for easy lift/close (will last approximately seven years, depending on use/climate).
- Trailer Exterior Length: 16.5'
- Trailer Exterior Width: 6'
- Interior Compartment Storage Space on Trailer: 44 cu. ft. and 50 cu. ft. (without gear).

Generator, AC Power:

- Proven industry generator is more efficient and reliable than propane.
- 8.5 kW diesel powered generator comes standard. Gasoline option available.
- Twenty gallon integrated fuel tank (approximately 36 hours run time without refueling).

Battery:

- Optima "yellowtop" battery 12v (group 31) sealed.
- Lasts up to two times longer than traditional flat-plate batteries.
- Ideal for sporadic use; when fully-charged it can sit unused for up to 12 months at room temperature (or below) and still start a vehicle.
- 15 times more resistant to vibration than traditional lead-acid batteries.
- Integral battery charger system includes smart 3 phase charger, which prevents over charging and drainage.
- Battery will charge on generator supply or with shore power.

ECU:

- Integrated ECU - 24,000 BTU cooling and heating.



109 sq. ft.

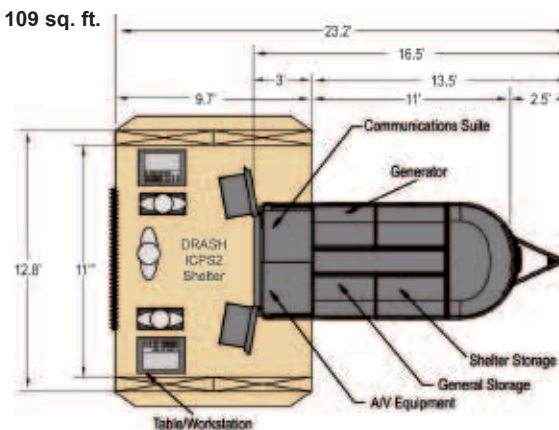

Footprints

The ICPS Trailer comes in the following Small, Medium, and Large sizes. Ranging in size from 109 to 214 square feet, all of the command post models have an interior height of 7.7 feet and an exterior height of 10.2 feet.

161 sq. ft.

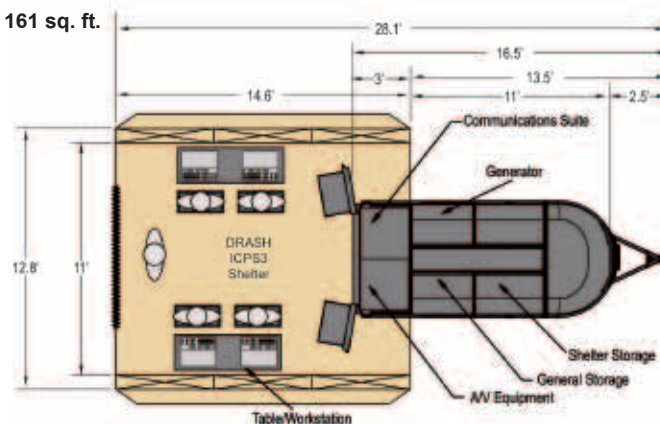

214 sq. ft.

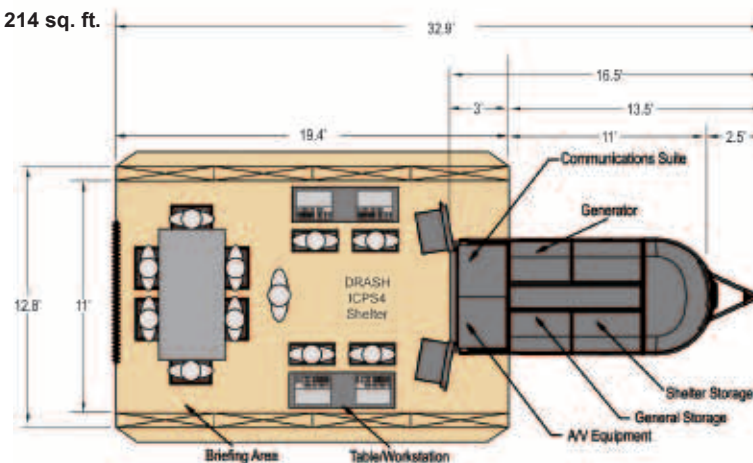

ICPS Trailer

From a command post to a mobile classroom, the ICPS Trailer can be outfitted for a wide range of applications. To ensure that personnel have just the space they need the ICPS offers between 109 and 214 square feet of usable space depending on model, while its cabinet can be customized to meet your unique storage needs.

ICPS Trailer as a Mobile Aid Station

Providing up to 214 square feet of usable space, the ICPS Trailer can be configured as a mobile aid station from which personnel can administer field treatment to victims of disasters or trauma. A refrigerator and plentiful storage space ensure that users can safely and properly store any necessary medical supplies.

ICPS Trailer as a Mobile Recruiting Station

Utilizing one of its optional communications packages and various floor layouts, the ICPS Trailer can be outfitted as a mobile recruiting station to help recruiting battalions build forces from any location. The ICP's shelter can also be integrated with other larger DRASH shelter models to increase workspace as needed.